

# PROPOSED STATION EXPANSION

Volga Fire Department



April 29, 2020

*Presented by:*

**VOGT + BELL**

**Engineering & Design**

*In Association with:*





# Mitch Vogt

*Project Manager*

- Candidate: BSE Civil Engineering  
University of Iowa 2020
- MBA Finance – Creighton University 2016
- BBA Finance – University of Iowa 2013
- Work Experience:
  - Berkshire Hathaway, Inc. 2013 – 2017
  - DGR Engineering 2018 - Present

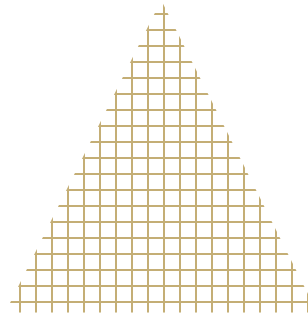

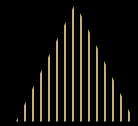

# Schuyler Bell

*Design Lead*

- Candidate: BSE Civil Engineering  
University of Iowa 2020
- Work Experience:
  - United States Navy – Builder 2011-2015

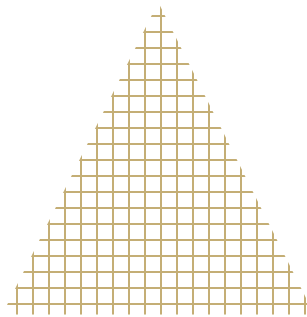
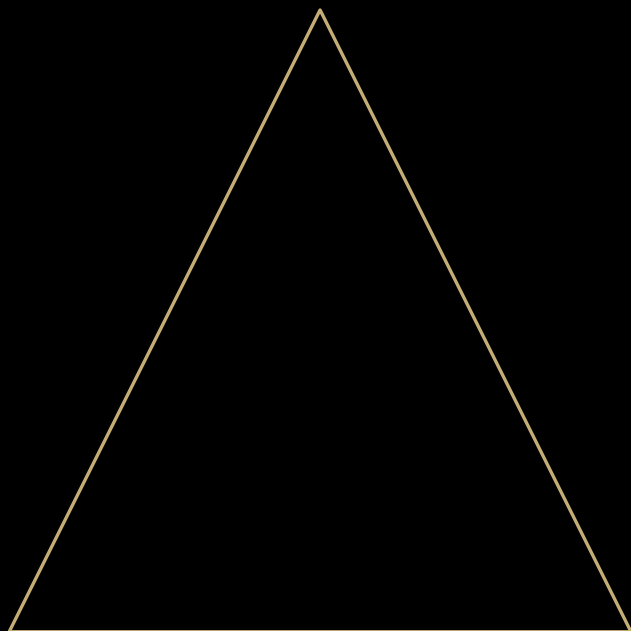

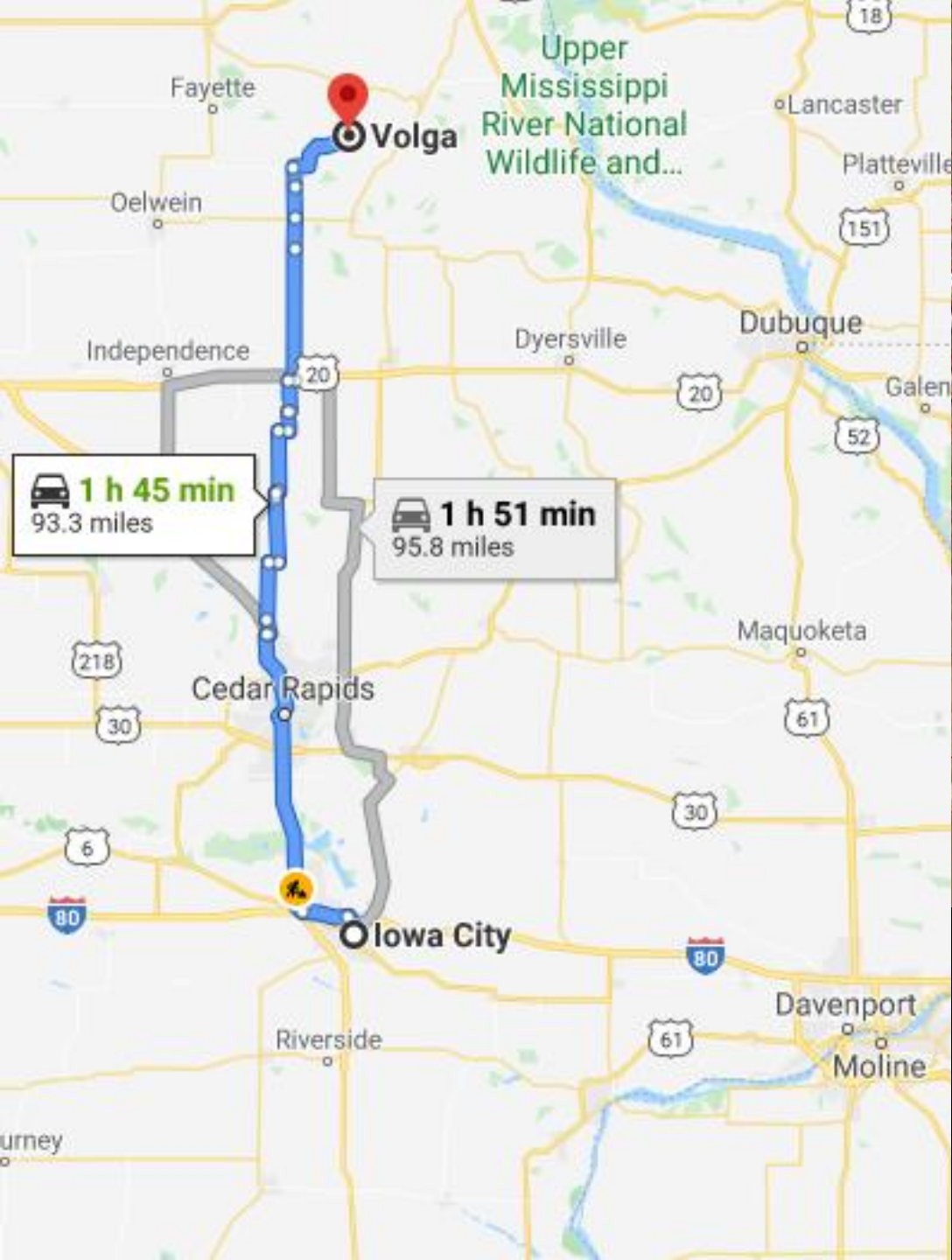

Project Location

# Volga, IA

*Population: 208*

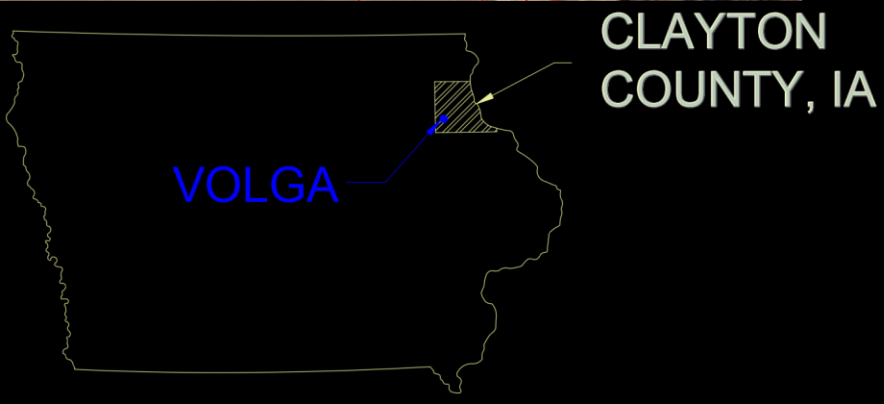

CLAYTON  
COUNTY, IA



# Volga Fire Department

Client



# Project Challenges

- Lack of Space
- Multiple uses of facility
  - Fire
  - EMT
  - Assembly Space
  - City Office
  - Storage
  - Emergency Shelter & Ops. Center
- Located in 100yr Flood Plain
- Limited Parking
- Volunteer Labor
- Site is logistically impractical



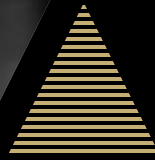

# Code



- 2015 IBC allows for 1 story, U Occupancy, Type IV Construction of up to *18,000 SF*  $\times$  *123%* = **22,104 SF** without fire sprinkler system.  
*Accessory Occupancies would be limited to 10% of Primary Occupancy.*

## Existing Building:

- Type IV Construction
- Non-sprinklered
- 3,600 SF *100% U Occupancy*

## Building Expansion:

- Type IV Construction
- Non-sprinklered
- +5,280 SF *100% U Occupancy*
- 8,880 SF Total

# Existing Floor Plan

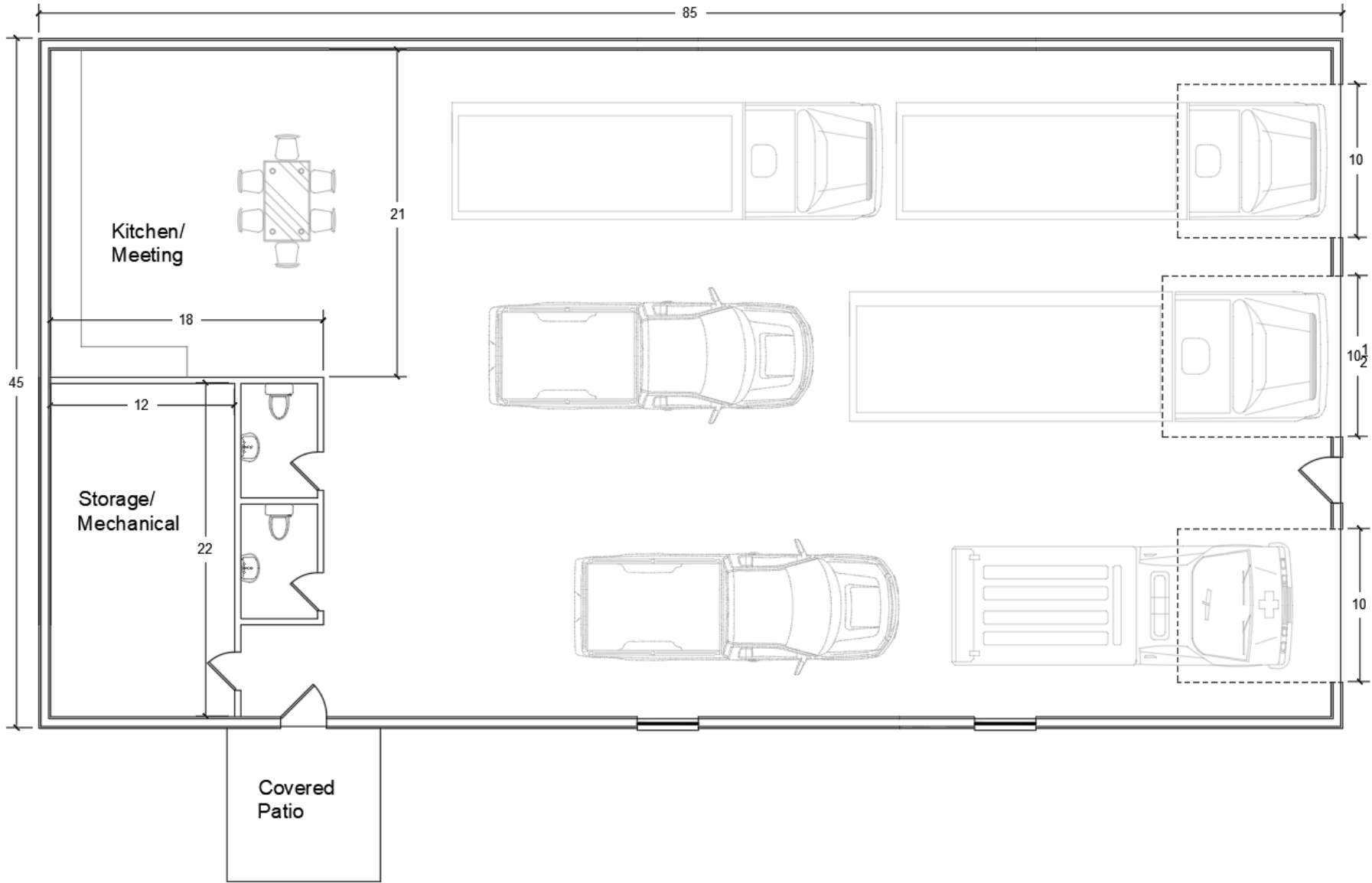

 <p><b>VOGT + BELL</b> Engineering &amp; Design</p>	
<p><b>THE UNIVERSITY OF IOWA</b> CIVIL AND ENVIRONMENTAL ENGINEERING 4105 SEAMANS CENTER FOR THE ENGINEERING ARTS AND SCIENCES 103 S CAPITOL ST IOWA CITY, IOWA 52242 PHONE: 319-335-5647 FAX: 319-335-5648 EMAIL: civil-hw@uiowa.edu</p>	
<p><b>IOWA</b> CIVIL &amp; ENVIRONMENTAL ENGINEERING</p>	
<p><b>VOLGA FIRE DEPARTMENT</b> <b>2020 STATION EXPANSION</b> 300 LAFAYETTE ST VOLGA, IA 52077</p>	
<p>PROJECT: CEE 4850 DATE: 11/17/2020 DRAWN BY: Mitch Vegt REVISOR: SHEET NAME: EXISTING FLOORPLAN SHEET NO.: <b>XX</b></p>	



**VOGT + BELL**  
Engineering & Design



**IOWA**  
CIVIL & ENVIRONMENTAL ENGINEERING



# Proposed Floor Plan

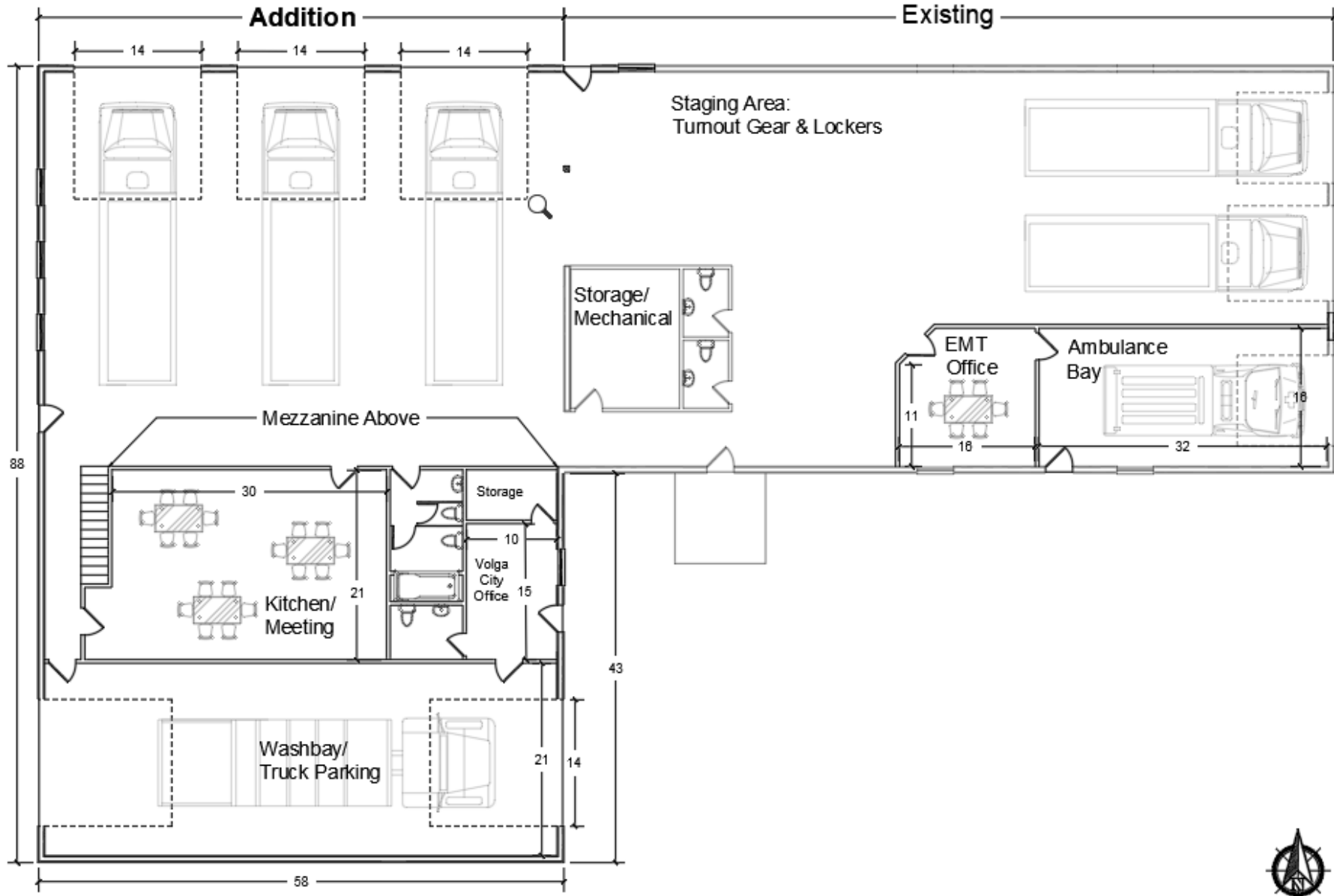

  
**VOGT + BELL**  
 Engineering & Design

**IOWA**  
 CIVIL & ENVIRONMENTAL  
 ENGINEERING

**VOLGA FIRE DEPARTMENT  
 2020 STATION EXPANSION**  
 300 LAFAYETTE ST  
 VOLGA, IA 52077

DATE:	11/17/2020
DESIGNER:	USA, W.P.
REVISION:	
SHEET NAME:	PROPOSED FLOORPLAN
SHEET NO.:	<b>XX</b>



**VOGT + BELL**  
 Engineering & Design



**IOWA**  
 CIVIL & ENVIRONMENTAL  
 ENGINEERING

# Proposed Site Plan

WHITE STREET

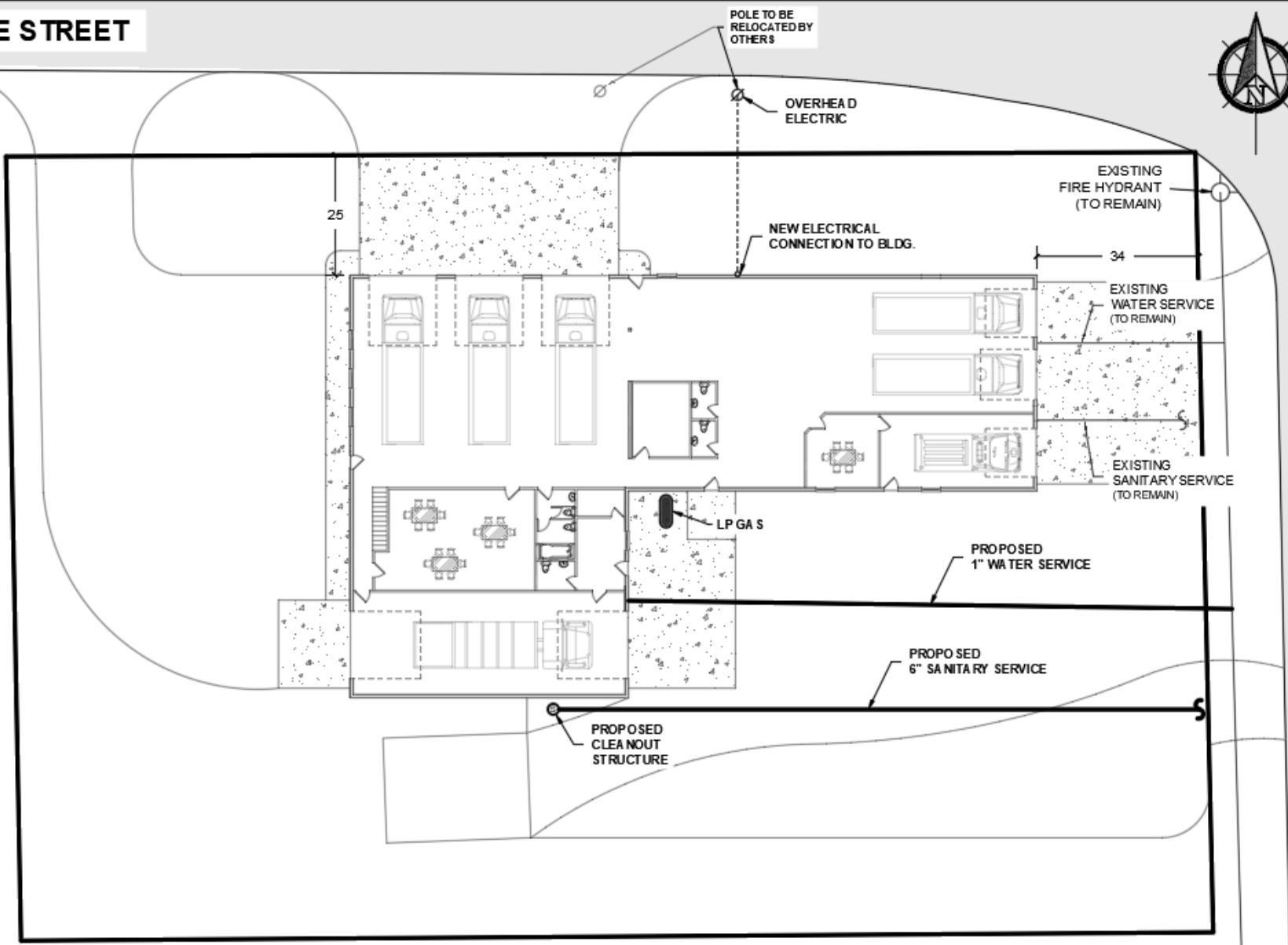

**VOGT + BELL**  
Engineering & Design

THE UNIVERSITY OF IOWA  
CIVIL AND ENVIRONMENTAL ENGINEERING  
4100 SEASONS CENTER FOR THE  
ENHANCING ARTS AND SCIENCES  
335 CONNELL  
IOWA CITY, IOWA 52242  
PHONE: 319.335.5443  
FAX: 319.335.5669  
EMAIL: [cbell@hawaii.edu](mailto:cbell@hawaii.edu)

**IOWA**  
CIVIL & ENVIRONMENTAL  
ENGINEERING

**VOLGA FIRE DEPARTMENT  
2020 STATION EXPANSION**

300 LAFAYETTE ST  
VOLGA, IA 52077

CONSULTING - NOT  
FOR CONSTRUCTION

LAFAYETTE STREET

PROJECT: 2019-0010  
DATE: 10/17/2019  
DRAWN BY: WSL/vlg  
REVISIONS:  
SHEET NAME:  
SITE  
UTILITY PLAN  
SHEET NO.:  
**C3.01**



**VOGT + BELL**  
Engineering & Design



**IOWA**  
CIVIL & ENVIRONMENTAL  
ENGINEERING

# Perspective

Addition  
5,280 SF

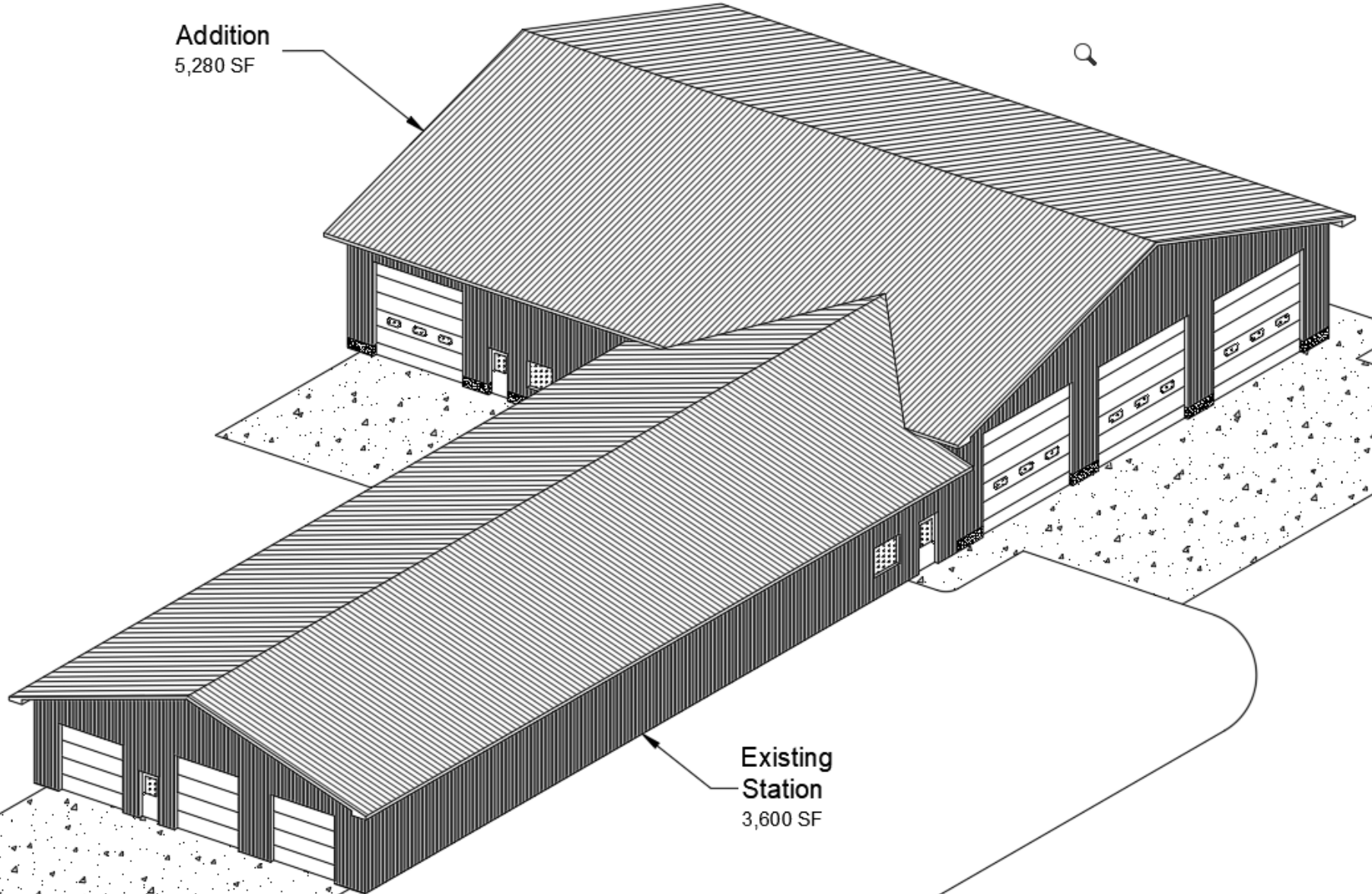

Existing  
Station  
3,600 SF

 <b>VOGT + BELL</b> Engineering & Design
<b>THE UNIVERSITY OF IOWA</b> <b>CYCALAD ENVIRONMENTAL ENGINEERING</b> 4105 SEAWALK CENTER FOR THE ENGINEERING ARTS AND SCIENCES 103 S CAPITOL ST IOWA CITY, IOWA 52242 PHONE: 319.335.9647 FAX: 319.335.9640 EMAIL: cycalad@iastate.edu
<b>IOWA</b> CIVIL & ENVIRONMENTAL ENGINEERING
<b>VOLGA FIRE DEPARTMENT</b> <b>2020 STATION EXPANSION</b> 300 LAFAYETTE ST VOLGA, IA 52077
PROJECT NO. 19-001-0001
PROJECT: FIRE 4893
DATE: 11/03/2018
DRAWN BY: [blank]
CHECKED BY: [blank]
REVISIONS:
SHEET NAME: ROOF PERSPECTIVE
SHEET NO. <b>XX</b>



**VOGT + BELL**  
Engineering & Design



**IOWA**  
CIVIL & ENVIRONMENTAL  
ENGINEERING

# Design Elements

## Apparatus Bays



# Design Elements

## Apparatus Bays



# Design Elements

*Apparatus  
Bays*



# Design Elements

*Apparatus Bays*



# Design Elements

## *Storage Mezzanine*





# Design Elements

*Storage Mezzanine*



# Design Elements

*Kitchenette*



# Design Elements

*Meeting Space*



# Design Elements

## *Meeting Space*



# Design Elements

## *Bunker Gear Lockers*



# Design Elements

*Bunker Gear  
Lockers*



# Design Elements



# Design Elements





# Design Elements



# Structural Narrative & Program (1)

**VOGT + BELL**  
Engineering & Design

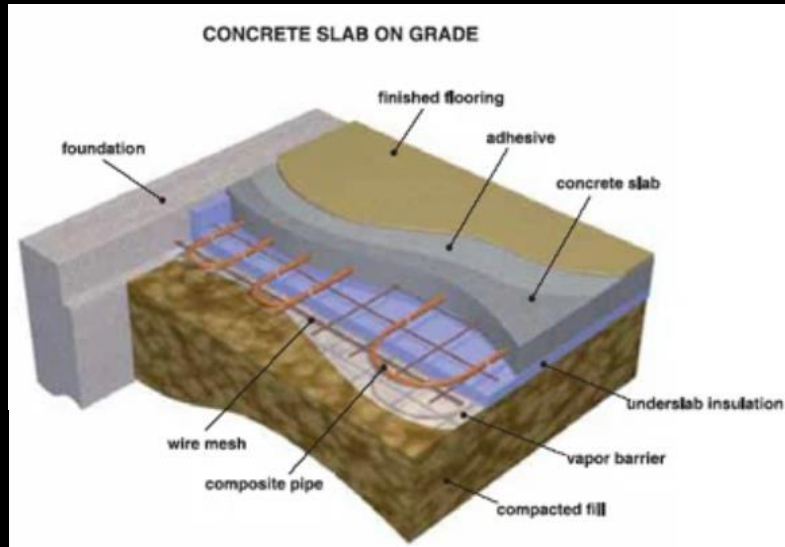

Footer centered on pilaster. Stem wall goes to edge of footer.

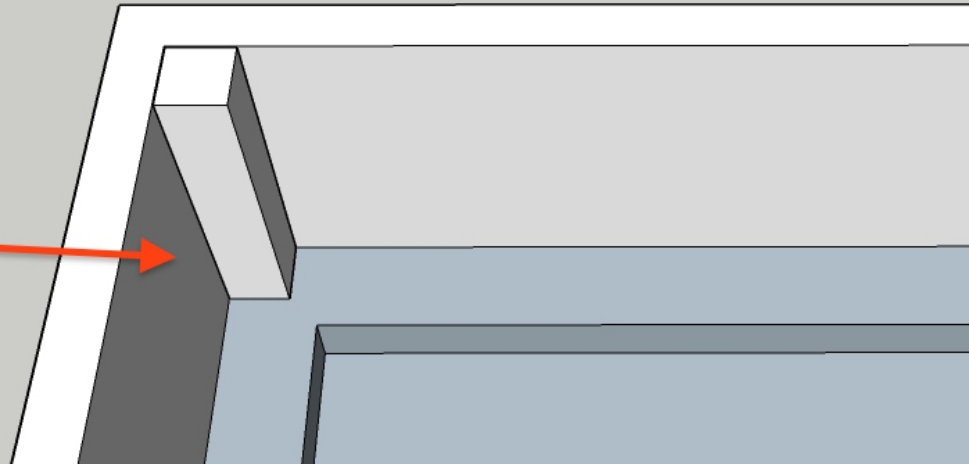

## Design Criteria and References:

The Volga Fire Station addition is being designed structurally in accordance with the 2016 Iowa State Building Code (2015 International Building Code). The 2016 Iowa State Building Code adopted the 2015 International Building Code by reference without any modifications that affect the structural aspects of this project. For purposes of this design narrative the references to applicable code will be based upon the 2015 IBC.

## Design Loads:

The facility is designed for the Dead Load of the structure and the following superimposed loads:

- Snow Load: *In accordance with IBC 2015 and ASCE 7-10 as follows:*
  1. Minimum Ground Snow Load 40 psf
  2. Typical Pitched Roof Snow Load 30 psf Uniform + Drift
  3. Risk Category IV
  4. Importance 1.0
- Roof Loads:
  1. Dead load (superimposed) 20 psf
  2. Live Loads 20 psf
- Main Floor Load (slab-on-grade)
  1. Live Load 100 psf
- Wind Load: *In accordance with IBC 2015 and ASCE 7-10 as follows:*
  1. Velocity 115 mph
  2. Exposure C
  3. Internal Pressure Coefficient 0.18
- Seismic Load: *In accordance with IBC 2015 and ASCE 7-10 as follows:*
  1. Risk Category IV
  2. Short Period Spectral Response Acceleration 0.077
  3. One-Second Period Spectral Response Acceleration 0.037
  4. Seismic Importance 1.0
  5. Soil Classification D (See Soils Report)
  6. Seismic Design Category A
- Deflection Limits
  1. Roof Framing (vertical deflection)
    - Live (or snow) Load L/360
    - Total Load L/240
- Retaining Walls (if required)
  1. Active Earth Pressure 60 lb/ft<sup>3</sup>

## Foundations and Interior Slab on Grade:

The building foundation will be conventional spread footings and 10" concrete foundation walls with six-inch depth of expected granular engineered fill below the slab and footings (to be verified by Geotechnical Report). Foundation walls will have integrated pilasters at each vertical column location (to ensure 3" clear cover of column anchors). A drain tile at the base of the engineered fill is recommended and may require a sump pit and pump at collection points.

Main level concrete floor slab in garaging areas is anticipated to be a reinforced 6" concrete slab-on-grade. The slab will be thickened as required at interior bearing walls. Floor slab in areas other than garaging areas will be a reinforced 4" concrete slab-on-grade. All concrete slabs will have control joints located at a maximum spacing of 15' on center. Vapor retarder will be specified below the interior slab on grade.

# Structural Narrative & Program (2)

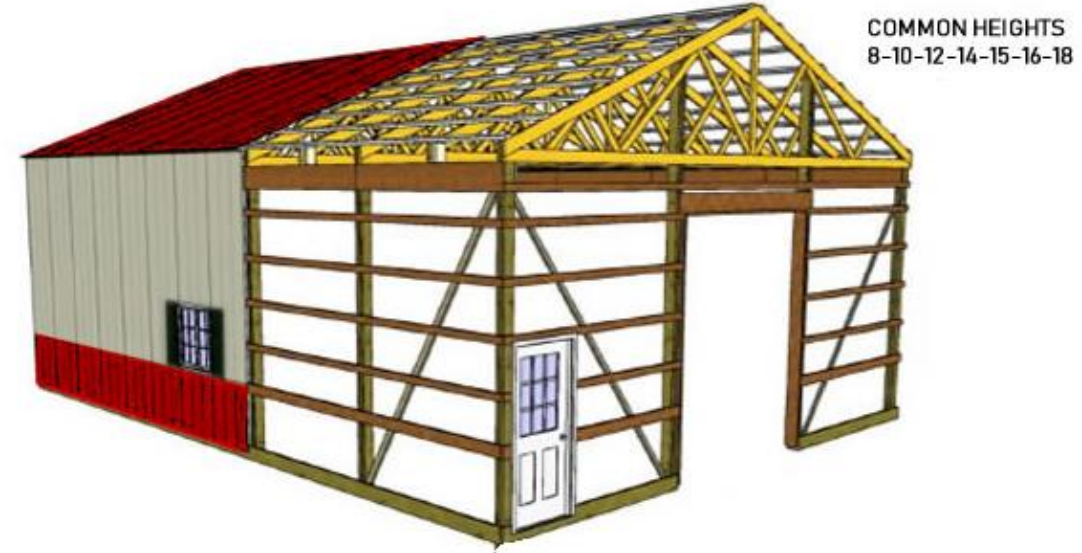
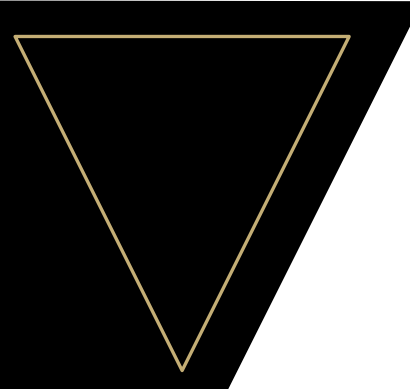

### Exterior Wall Construction:

Exterior wall construction will be primarily horizontal 2x4 girts at 3' OC. Walls will be spray-foam insulated and sheathed on both sides in corrugated steel panels.

### Building Expansion Joints:

A building expansion joint is anticipated along the junction of the addition to the existing building.

### Site Retaining Walls:

The extent of retaining walls for the project is unknown. It appears likely that some walls will exist adjacent to exterior slabs-on-grade and/or culvert locations.

### Materials:

The structure will be designed for the following materials strengths to be used in construction:

- Concrete ( $f'_c$ ):
  1. Foundation/Retaining Walls & Footings
  2. Interior Slab-on-Grade
  3. Exterior Concrete
- Structural Wood:

### Special Inspections:

Structures designed in accordance with IBC 2015 are required to have special inspections performed during the construction of the project. Special Inspections are quality control inspections and testing that are performed on a periodic basis to ensure the adequacy of construction. The Facility will have special inspections performed during the construction of the project meeting the requirements of IBC 2015 as follows:

- Concrete Construction
  - Table 1705.3
- Soils
  - Table 1705.6

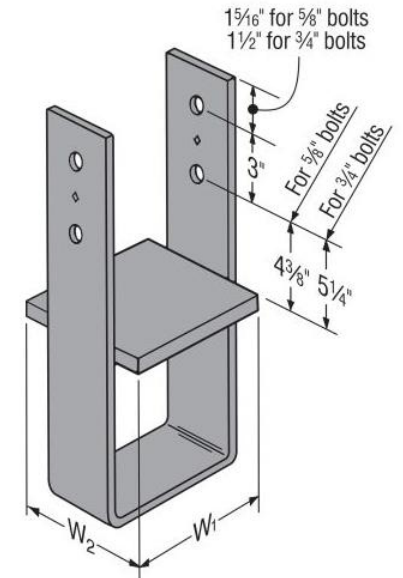
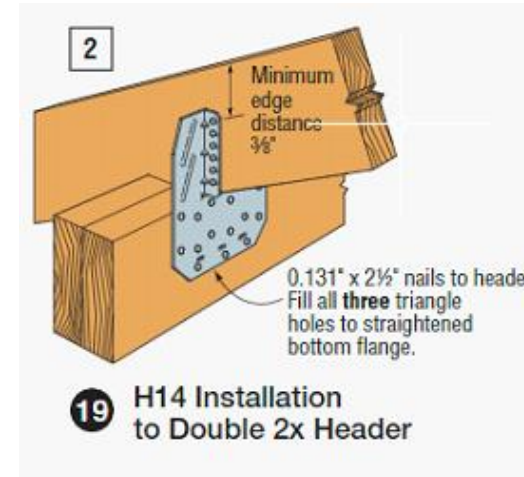

Configuration of all other CB sizes



# Structural Narrative & Program (4)

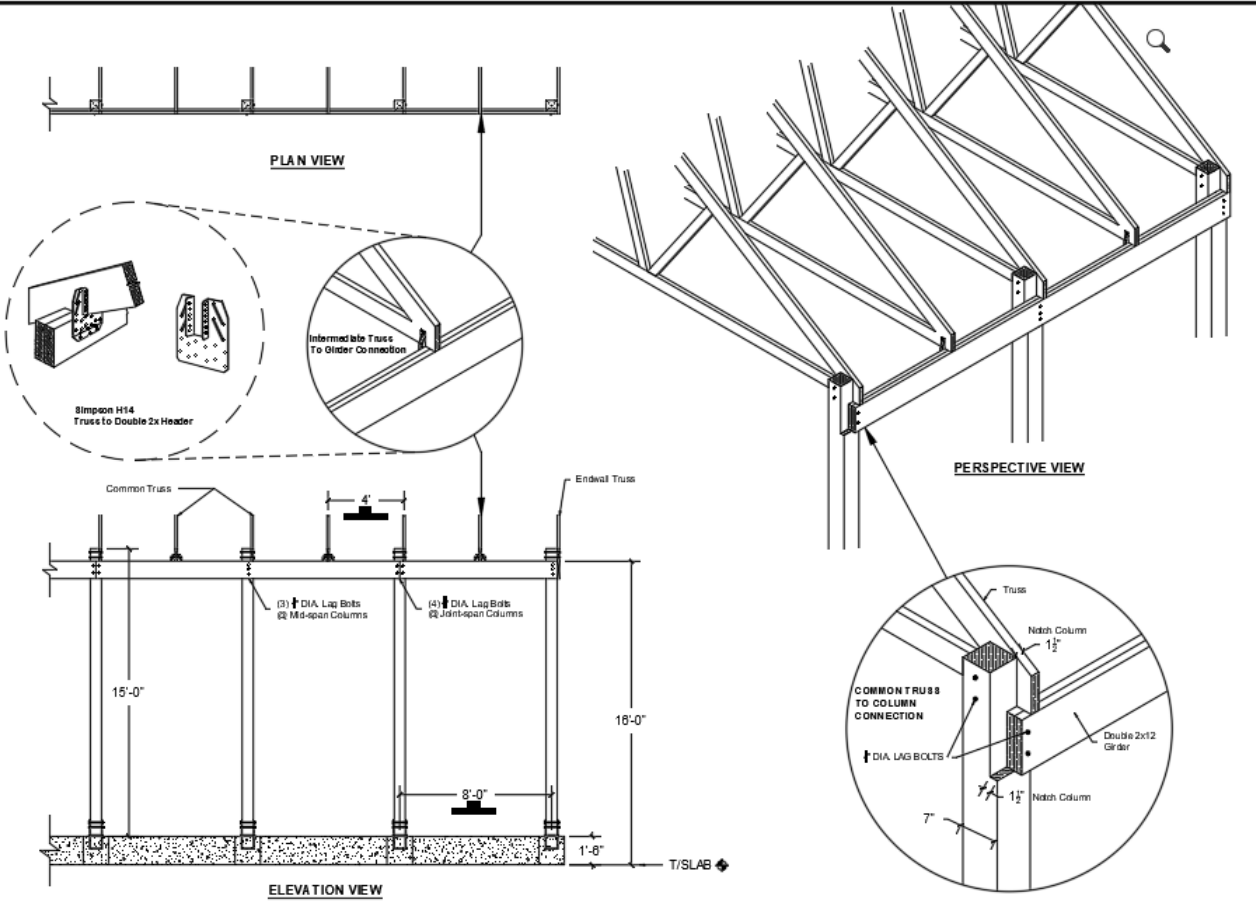

THE UNIVERSITY OF IOWA  
 CIVIL & ENVIRONMENTAL ENGINEERING  
 407 SEAWARD CENTER FOR THE ENVIRONMENTAL SCIENCES  
 103 S. LAUREL ST  
 IOWA CITY, IOWA 52242  
 PHONE: 319.335.3660  
 FAX: 319.335.3660  
 EMAIL: info@vogtandbell.com

**VOGT + BELL**  
 CIVIL & ENVIRONMENTAL ENGINEERING & DESIGN

**VOLGA FIRE DEPARTMENT**  
**2020 STATION EXPANSION**  
 300 LAFAYETTE ST  
 VOLGA, IA 52077

Project: 2024-000  
 Date: 11/10/2024  
 Drawn by: [redacted]  
 Address: [redacted]  
 SHEET NAME: STRUCTURAL DETAILS  
 SHEET NO.: **XX**

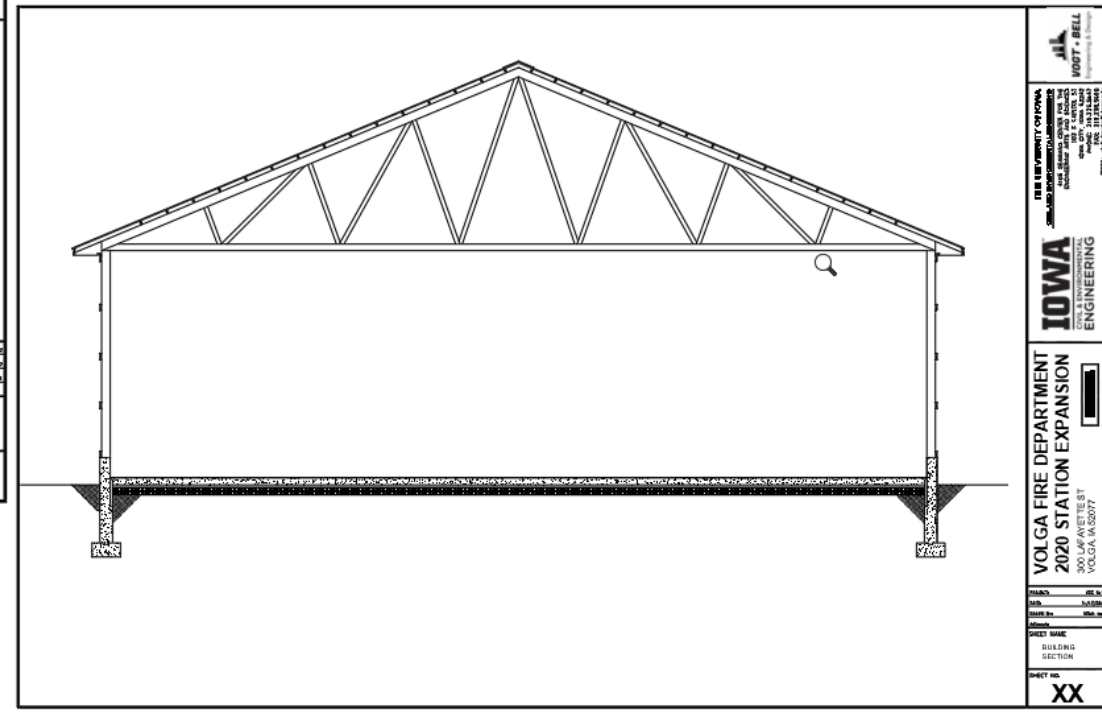
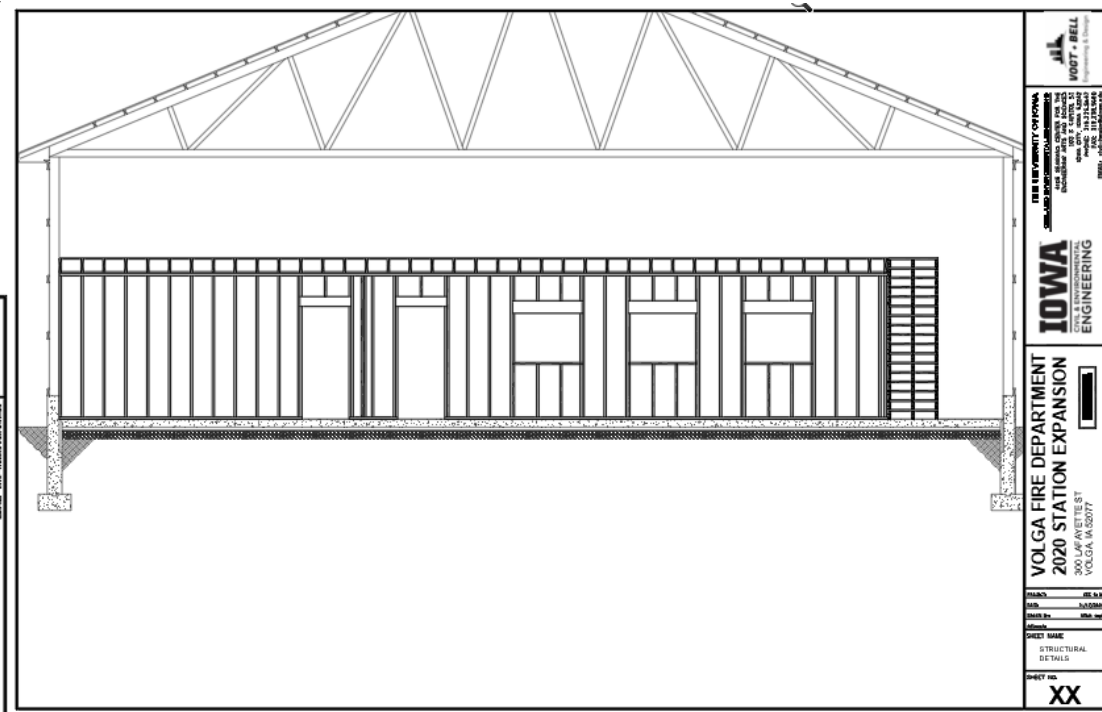

**VOGT + BELL**  
Engineering & Design

# Mechanical Narrative & Program (1)

**VOGT + BELL**  
Engineering & Design

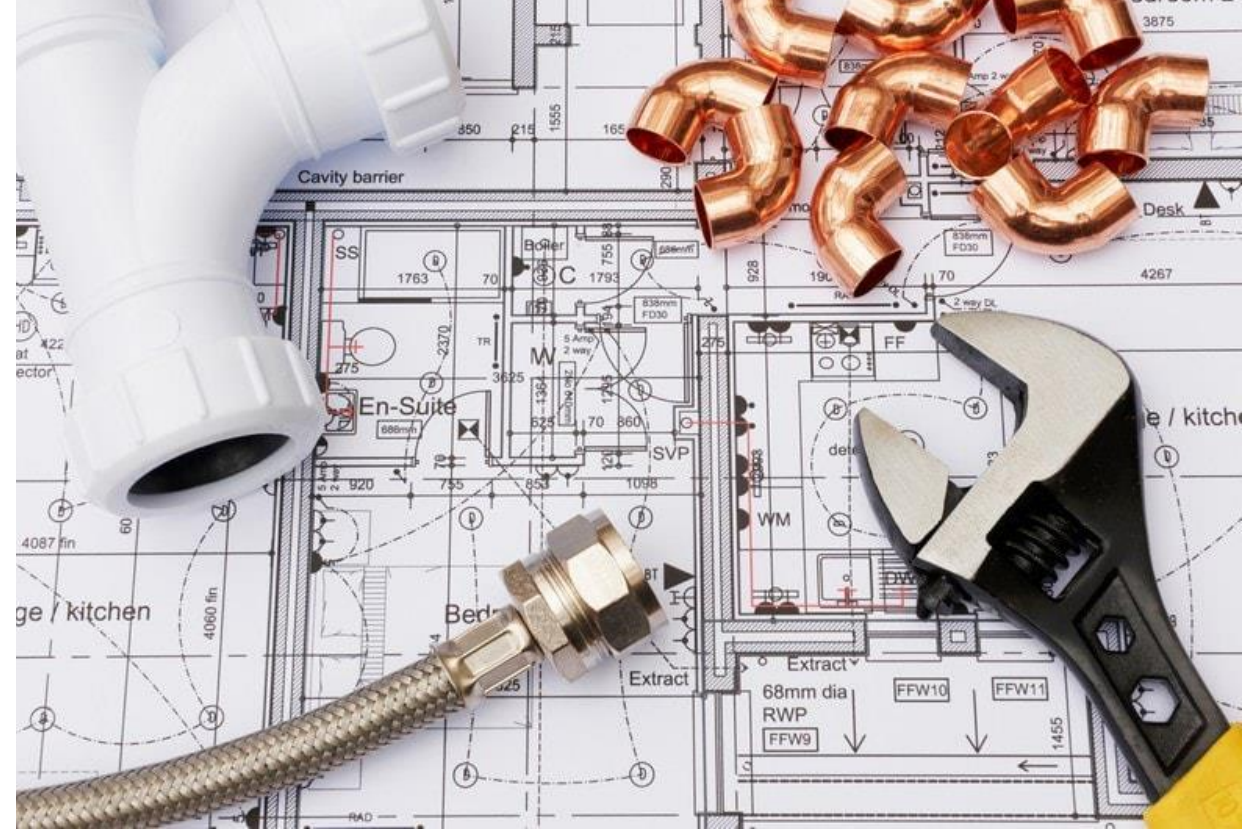

## HVAC, PLUMBING, AND FIRE PROTECTION SYSTEMS

### GENERAL

- Applicable Codes:
  - All work, materials, and installations shall be in compliance to the appropriate state and local codes, regulations, and enforcing agencies as listed below:
    - 2015 International Building Code*
    - 2015 International Mechanical Code*
    - 2015 Uniform Plumbing Code & Iowa Administrative Code 641-25*
    - 2015 International Fire Code*
    - 2012 International Energy Conservation Code/ASHRAE 90.1-2010*
    - NFPA*
  - Ventilation performance shall be in accordance with ASHRAE 62-2016
- Design Conditions:
  - The outdoor design temperature for comfort cooling shall be based on the 0.4% dry bulb and comfort heating shall be based on the 99% dry bulb temperature. Design conditions are as follows:
    - Elevations: All equipment performances shall be based on a minimum of 3,878 ft. above sea level.
    - Latitude: 43.43 degrees north
    - Outside Design Temperatures:
      - Summer 91.5 °F (DB), 73.7 °F (WB)
      - Winter -11.3 °F (DB)
    - Space Design Temperatures:
      - Summer 78
      - Winter 68
      - Relative Humidity 50%

# Mechanical Narrative & Program (2)

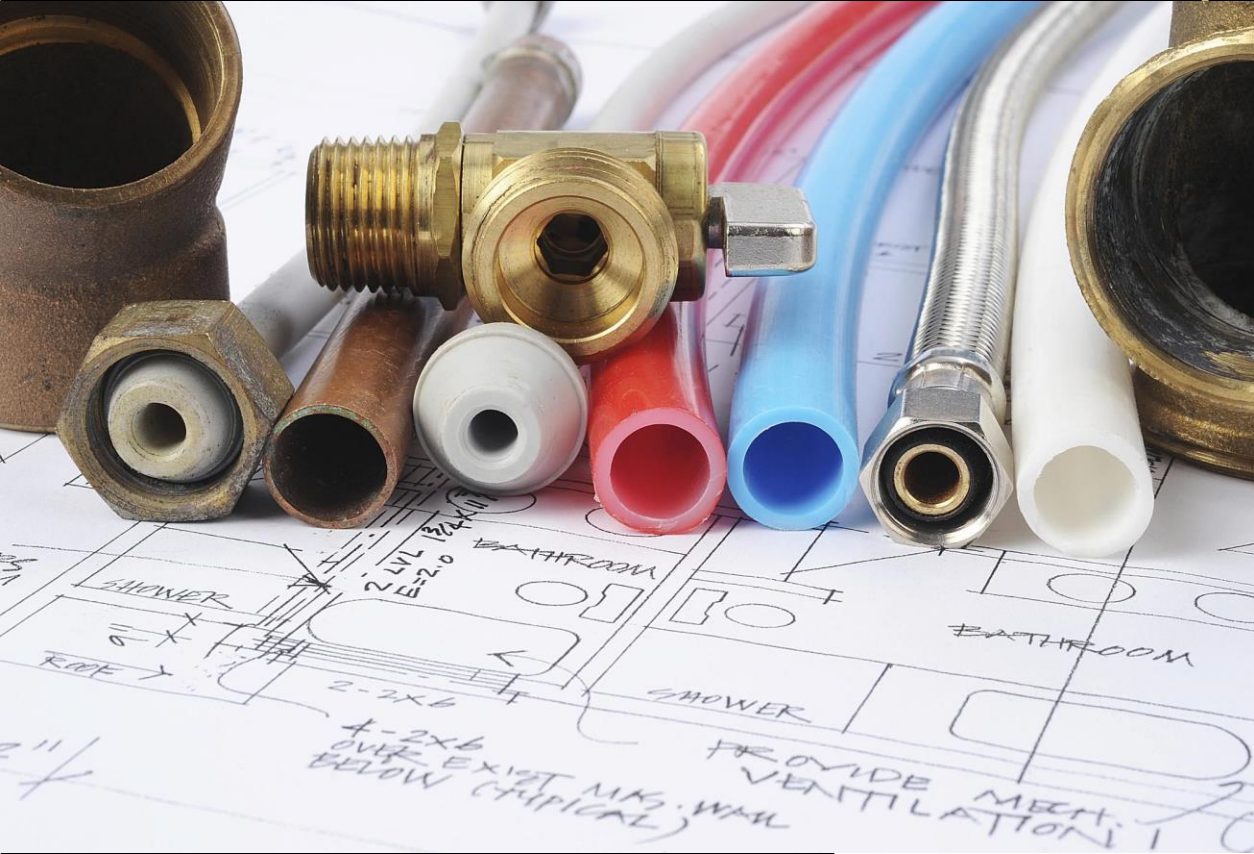

## PLUMBING SYSTEMS

- Special Services:
  - Natural Gas and LP piping shall be standard black steel, Schedule 40 with plain ends for welding over 2" with welded fittings as recommended by ASTM. Gas piping 2" and less shall be standard black steel, Schedule 40 with screw ends and screwed black malleable fittings.
    - LP gas will be provided to fuel gas-fired mechanical equipment.
- Sanitary:
  - Sanitary sewer and vent piping will be PVC plastic Schedule 40 pipe, except where the piping requires a fire rating, in which plenum rated piping will be used.
    - Floor drains will be installed where required throughout the facility. Areas include Mechanical Equipment rooms, Custodial rooms, Kitchen areas, and Restrooms, and as requested.
- Water Service:
  - Existing water service and 3" fire fill standpipe will remain unchanged and in service. New 1" water service will supply building addition.
    - Domestic water service piping in the building (underground) shall be schedule Type "K" copper pipe. The static pressure at finished floor will be a minimum of 65 psig required for domestic water design.
    - Domestic water piping (Hot, Circulating Hot and Cold Water) in building (above ground) shall be insulated Type "L" copper pipe. Fittings will be wrought copper with solder joints. The piping will be concealed in walls and ceilings of finished areas. Piping will be exposed and mounted directly to steel ceiling sheathing in garaging areas. As an alternate, Pex Type-A tubing will be allowed at
- Storm Drainage:
  - Storm drainage shall be plumbed from eavestrough gutters and 5" downspouts which will daylight to the site storm drainage system.
- Plumbing Fixtures:
  - Water closets and urinals shall be white vitreous china.
    - All water closets will be wall-hung type for ease of cleaning
    - Fixtures will be standard and/or ADA compliant where required.
    - Water conservation is intended to be achieved by using pint flush urinals and low flow water closet flush valves.
    - Flush valves shall be manual or automatic operated assemblies.
  - Lavatories shall be white vitreous china.
    - Counter style and/or wall hung lavatories with hard wired sensor operated faucet assemblies will be provided throughout the facility. Manual single lever faucet assemblies will be provided where requested.
    - Thermostatic mixing valves shall be provided serving public lavatories.
    - All lavatories with exposed supply and drain tailpieces will be provided with safety covers.
  - Sinks shall be stainless steel counter style fixtures.
    - Sinks will be provided with hi-arc swivel faucets with single lever handles.
    - Sinks within break rooms shall be provided with hand sprays and water supply to coffee makers and refrigerators.
  - Custodial areas shall be equipped with a 24"x24" floor mop sink with wall mounted faucet/hose assembly.
  - Exterior freeze-less wall hydrants shall be provided on each side of the facility.
  - Interior hose bibs shall be provided for areas requiring routine cleaning where requested.

# Mechanical Narrative & Program (3)

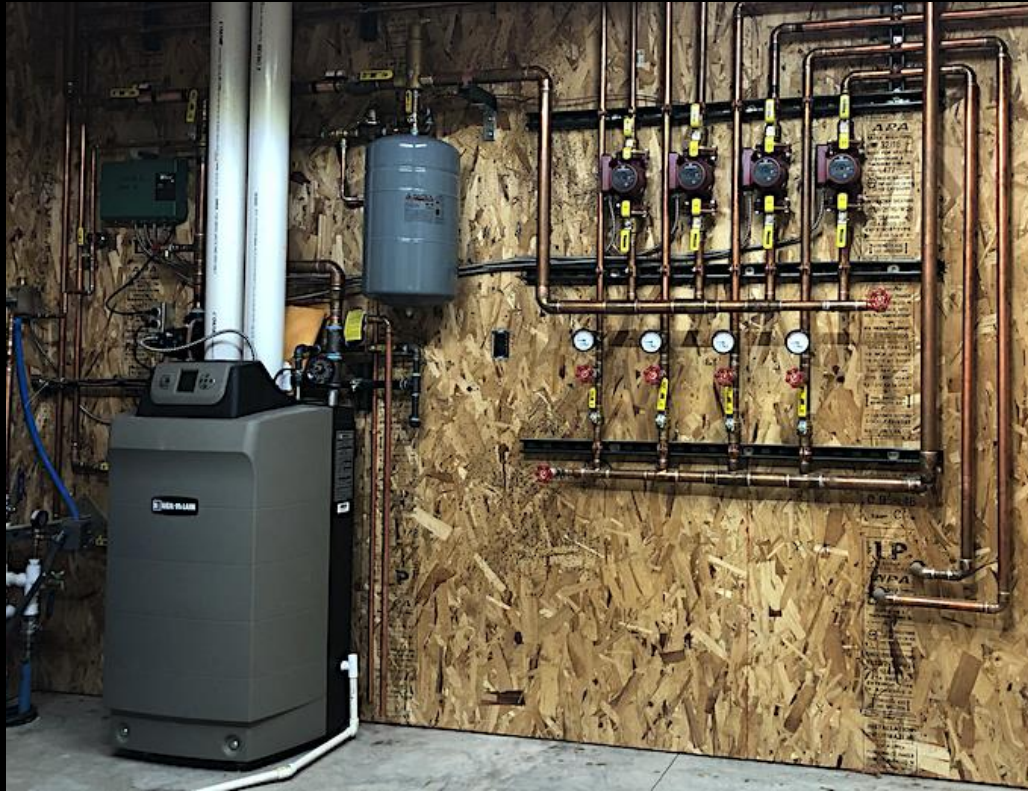

## HEATING, VENTILATION, AND AIR CONDITIONING (HVAC)

- Mechanical systems will be a combination of existing central air and new hydronic radiant systems.
  - SYSTEM 1 (Existing) – Gas-fired furnaces (2), each with dedicated outdoor AC condenser.
  - SYSTEM 2 (New) – Commercial outdoor condenser serving multiple Variable Air Volume (VAV) air handlers. Each VAV handler will provide cooling to a dedicated space within the new facility. "Wash Bay" will be heated but not cooled. Hot water (hydronic) shall provide heating to all new spaces via radiant floor heat. Hot water shall be generated by LP fired, high efficiency boilers. Multiple boilers shall provide redundancy and system pumps with variable frequency drives will serve the heating loops, reducing energy during times when partial loads are required. Pumps will be controlled in an alternating lead/lag sequence.
- Mechanical Ventilation:
  - Fresh air ventilation requirements shall be provided through air-to-air heat exchangers with variable frequency drives.
    - Energy efficiency for the air distribution system will recover energy from the exhausted air to accommodate the required fresh air ventilation throughout the facility.
    - The energy recovered will be used to either preheat or pre-cool the outside air as required before it enters the individual variable refrigerant units.
    - The exhaust airflow from the building will be controlled based on building space static pressure and/or via air flow stations set to match the intake air.

## TEMPERATURE CONTROL SYSTEM

- Automatic temperature and interlocking of the ventilation equipment, heating, and cooling systems will be accomplished by a Building Automation System (BAS).

## TEST AND BALANCE

- Air and water balancing for mechanical systems shall be performed by a NEBB certified and balancing contractor.



# Electrical Narrative & Program

## GENERAL

- Applicable Codes:
  - All work, materials, and installations shall be in compliance to the appropriate state and local codes, regulations, and enforcing agencies as listed below:
    - 2015 International Building Code*
    - 2015 International Mechanical Code*
    - 2015 Uniform Plumbing Code & Iowa Administrative Code 641-25*
    - 2015 International Fire Code*
    - 2012 International Energy Conservation Code/ASHRAE 90.1-2010*
    - NFPA*

## ELECTRICAL SERVICE AND DISTRIBUTION:

- All electrical work will be designed to comply with the 2017 National Electrical Code.
- Surge protection devices (SPD's) will be provided on any new panelboards being installed as part of this project.
- Feeders to panels shall be designed around copper, however aluminum feeders can be considered as a cost savings measure if desired by the Owner. Where aluminum conductors are used cable shall be AA8000 series alloy and termination fittings will be required to be listed with that type of conductors. All other cables and wiring shall be copper. All power from panelboards be run in conduit to junction boxes within rooms served. We can discuss if it makes sense to then allow MC cable to be used to feed receptacles, lights and switches or to use conduit exclusively. Kitchen and Mechanical equipment should all be fed using conduit and wire (no MC) to assist in change out and replacement of different equipment. Minimum branch circuit wiring shall be 12AWG conductors with upsizing of wire based on wire lengths over 75 feet. All feeders and branch circuits shall have a dedicated equipment grounding conductor installed.
- All 120V duplex receptacles shall be 20A specification grade type. General purpose outlets shall be provided in similar fashion as existing offices unless otherwise directed by the Owner.

## EMERGENCY POWER:

- Interior and exterior egress lighting shall be provided by way of individual battery packs within selected LED fixtures. The lumen output from these emergency fixtures shall such that egress pathways are lit to meet code requirements.
- All exit lights shall be provided with Nickel-Cadmium batteries with self-diagnostics.

## EXTERIOR LIGHTING:

- Exterior building mounted light fixtures will be LED style, most likely design around a Lithonia Model DSXW1 LED fixture.
- Exterior lights will be controlled by way of astronomical clock system that is part of the DDC control system so they only operate when needed to conserve on energy. A photo sensor shall be provided to also control exterior lighting for overcast days when natural light may be low prior to sunset and possibly after sunrise.



## INTERIOR LIGHTING:

- Standards of Design:
  - Room Color/Reflectance:
    - Quantity of Lighting is very much dependant on Room Colors and the Reflectances of those colors. Minimum reflectance should be as follows: Ceiling 80%; Walls 50%; and Floor 20%. ASHRAE design guide for energy efficient buildings recommend ceiling reflectance's of 80% plus with 90% being recommended for indirect lighting. They also recommend wall reflectance's of 70%.
  - Quantity of Light:
    - Private Offices; Open Office Areas; Commons and Meeting Rooms will be provided with approximately 50 footcandles of light.
  - Uniformity of Lighting:
    - Average to minimum lighting ratio not to exceed 3:1.
    - Maximum to minimum lighting ratio not to exceed 10:1.
  - Color Rendering:
    - Color Rendering Index (CRI) of a minimum of 80.
- Private Office Lighting:
  - Lighting in Private Offices will be provided by way of 2X4 LED volumetric troffers similar to Lithonia BLT series. These fixtures deliver superb performance lighting performance and are extremely energy efficient delivering in the range of 115 to 120 lumens per watt.
- Open Office Area; Commons and Meeting Room Lighting:
  - Again lighting of these areas will be LED type fixtures. The Open Office areas would appear to lend themselves to linear direct/indirect lighting matching similar past design practice. The Commons and Meeting Room Areas may deserve a little more up scale lighting design depending on Owner preference. Linear direct/indirect would also be appropriate.
- Lighting Controls:
  - Light Switches shall be installed in all rooms to provide a manual means to manually turn off lights within each room. Since LED fixtures inherently allow dimming, the switches will also be provided with diming capabilities to allow the user to select the lighting level they desire.
  - Occupancy sensors shall be utilized in offices, storage rooms, corridors, restrooms, meeting room, etc. for additional energy savings.

# Estimated Project Costs

- Structural
  - Foundation
  - Framing

- Mechanical
  - Plumbing
  - HVAC
- Electrical

## Project Cost

- Structure Materials = \$119,000
  - Plumbing, Mechanical, & Electrical Materials = \$33,000
  - Engineering Consulting Fees = \$30,000
  - Labor = Volunteered
- TOTAL (Building) = \$182,000**

Material	Quantity	Unit price	Total cost
2x4 DFL Select Structural (ft)	5515	0.6945	\$3,830.17
2x6 DFL Select Structural (ft)	2309	0.9945	\$2,296.30
2x8 DFL Select Structural (ft)	1445	1.2845	\$1,856.10
2x4 Pressure Treated (ft)	225	0.8495	\$191.14
2x4 SPF No. 2 (ft)	2884	0.6595	\$1,902.00
2x12 SPF No. 2 (ft)	847	2.6495	\$2,244.13
7x7x14 PSL (ft)	462	19.02	\$8,787.24
4x8x3/4 OSB (ea.)	33	19.69	\$649.77
4x8x1-1/8 OSB (ea.)	4	49.99	\$199.96
CB 7-1/8-7 connector (ea.)	33	66.86	\$2,206.38
H14 anchor (ea.)	46	2.86	\$131.56
Cellulose insulation (ea.)	320	13.5	\$4,320.00
Spray-foam insulation (ft <sup>3</sup> )	1446	8.4	\$12,146.40
Rigid foam board (ea.)	160	34.99	\$5,598.40
Overhead door (ea.)	5	1638	\$8,190.00
Exterior walk-in door (ea.)	3	200	\$600.00
Interior door (ea.)	9	109	\$981.00
Window (ea.)	7	115.69	\$809.83
Metal cladding (ea.)	330	42.55	\$14,041.50
Glasteel (ft <sup>2</sup> )	928	1.67	\$1,549.76
Gypsum board (ea.)	135	10.14	\$1,368.90
Concrete (yd <sup>3</sup> )	151	97	\$14,647.00
Steel reinforcement (ea.)	600	13.79	\$8,274.00
Fasteners (tot.)	2000	1	\$2,000.00
Sum =			\$98,821.53
Waste =			1.2
Total =			\$118,585.84

Plumbing, Electrical, & Mechanical				
Item	Quantity	Unit	Unit Price	Total Cost
1/2" Pex Tubing	10000	lf	0.2044	\$ 2,044.00
1/2" Copper	100	lf	0.68	\$ 68.00
3/4" Copper	100	lf	1.1	\$ 110.00
1" Copper	100	lf	1.841	\$ 184.10
Valves & Fittings	1	L.S.	2500	\$ 2,500.00
Radiant 1/25 HP Circulator Pump	6	each	75.64	\$ 453.84
Radiant Zone Control	6	each	57.84	\$ 347.04
150k BTU Condensing Boiler	2	each	1682.1	\$ 3,364.20
Radiant Control Integration & Panel	1	each	2000	\$ 2,000.00
Lavatory	3	each	200	\$ 600.00
Water Closet	3	each	300	\$ 900.00
5' Shower	1	each	400	\$ 400.00
2" DWV PVC	75	lf	0.39	\$ 29.25
4" DWV PVC	75	lf	0.98	\$ 73.50
6" Sewer PVC	200	lf	2	\$ 400.00
PCV Fittings	1	LS	500	\$ 500.00
Cleanout Structure	1	each	500	\$ 500.00
Air Conditioning Condensor	2	each	2750	\$ 5,500.00
Condensor Line Set	2	each	150	\$ 300.00
AC Air Handler	2	each	750	\$ 1,500.00
Light Fixtures	40	each	100	\$ 4,000.00
Door openers	5	each	250	\$ 1,250.00
12 Gauge Romex	3000	lf	0.2	\$ 600.00
Channel Drain	50	lf	100	\$ 5,000.00
				<b>\$ 32,623.93</b>

# Thank You



 **LinkedIn**

 **Email**  
mitchell-vogt@uiowa.edu

 **Phone**  
712-541-5399

**VOGT + BELL**  
Engineering & Design

**IOWA**  
CIVIL & ENVIRONMENTAL  
ENGINEERING

